

3-JAW WEDGE TYPE NON THROUGH HOLE POWER CHUCK (WITH ADAPTOR)

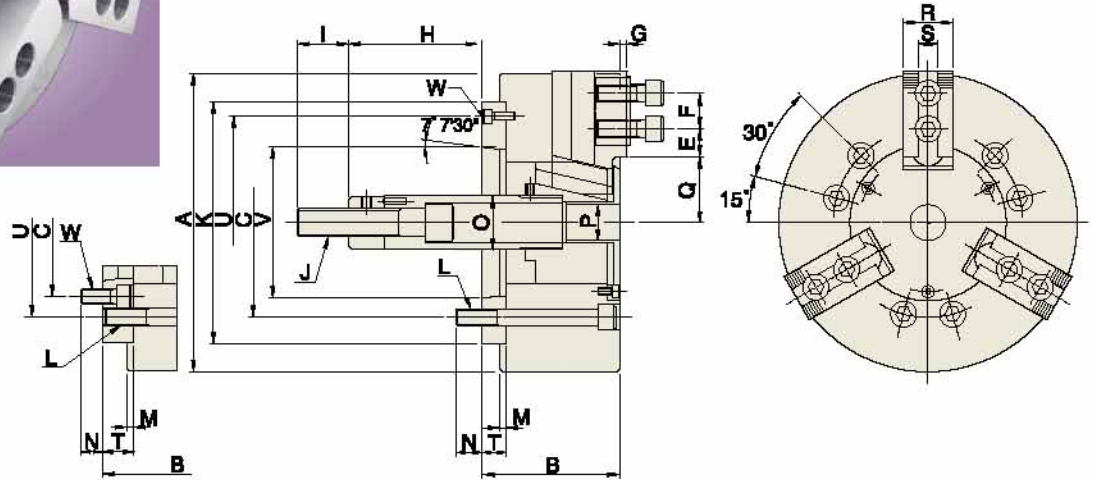

Fig 2.

Fig 1.

規格 SPECIFICATIONS

型式 Model	爪行程 Jaw Stroke (mm)	柱塞行程 Plunger Stroke (mm)	最大推力 Max. Pull Force (kgf)	最大夾持力 油壓壓力 Max. Gripping (kgf)/(kgf/cm ²)	最高轉速 Max. Speed (r.p.m)	重量 Weight (kg)	慣性矩 Moment of Inertia (kgf.m ²)	適合油壓缸 Matching Cylinder	適合之軟爪 Matching Soft Jaw	適合之硬爪 Matching Hard Jaw
V-206A5	8.5	20	1835	5253/25.5	5270	12.5	0.045	MH105	HC06	HJ06
V-208A6	8.8	21	2549	7548/24.5	4765	24.4	0.137	MH125	HC08	HJ08
V-210A6	8.8	25	2957	10013/28.6	4010	40.65	0.3	MH125	HC10	HJ10
V-210A8	8.8	25	2957	10013/28.6	4010	37.15	0.3	MH125	HC10	HJ10
V-212A8	10.5	30	4181	15807/27.5	3380	61.75	0.725	MH150	HC12-1	HJ12-1
V-215A8	16	35	8362	25391/30.6	3000	105	1.8	MH150	HC15-1	HJ15-1
V-215A11	16	35	8362	25391/30.6	3000	103	1.8	MH200	HC15-1	HJ15-1

尺寸表 DIMENSIONS

型式 Model	V-206 A5	V-208 A5	V-208 A6	V-210 A6	V-210 A8	V-212 A8	V-215 A8	V-215 A11
A	165	210	210	254	254	304	381	381
B	84	103	97	109	102	118	141	130
C	104.78	104.78	133.35	133.35	171.45	171.45	171.45	235
F	20	25	25	30	30	30	43	43
K	140	170	170	220	220	220	300	300
L	6-M10	6-M12	6-M12	6-M16	6-M16	6-M16	6-M16	6-M20
M	5	5	5	5	5	6	6	6
N	14	13	18	18	25	25	24	32
P	21	21	25	34	34	34	-	-
T	15	23	17	25	18	18	33	22
V	82.563	82.563	106.375	106.375	139.719	139.719	139.719	196.889
U	116	133.35	150	171.45	190	190	235	260
參考圖	Fig-1	Fig-2	Fig-1	Fig-2	Fig-1	Fig-1	Fig-2	Fig-1

尺寸表 DIMENSIONS

型式 Model	V-206 A5	V-208 A5	V-208 A6	V-210 A6	V-210 A8	V-212 A8	V-215 A8	V-215 A11
E	Max.	18	22.5	22.5	37.5	37.5	47	50.25
	Min.	7.5	9	9	10.5	10.5	11	23.25
G	4	5	5	5	5	5	2	2
H	Max.	89.6	109	115	133	140	145	71
	Min.	69.6	88	94	108	115	115	36
I	36	36	36	36	36	36	55	55
J	M16x2.0	M20x2.5	M20x2.5	M20x2.5	M20x2.5	M20x2.5	M30x3.5	M30x3.5
O	34	38	38	45	45	50	60	60
Q	Max.	37.8	46.3	46.3	51.1	51.1	61	77.5
	Min.	33.5	41.9	41.9	46.7	46.7	55.75	69.5
R	31	35	35	40	40	50	50	50
S	12	14	14	16	16	18	25.5	25.5
W	3-M6	3-M10	3-M6	6-M12	6-M8	6-M8	6-M16	3-M10
參考圖	Fig-1	Fig-2	Fig-1	Fig-2	Fig-1	Fig-1	Fig-2	Fig-1