

3-JAW WEDGE TYPE NON THROUGH HOLE
POWER CHUCK (WITHOUT ADAPTOR)

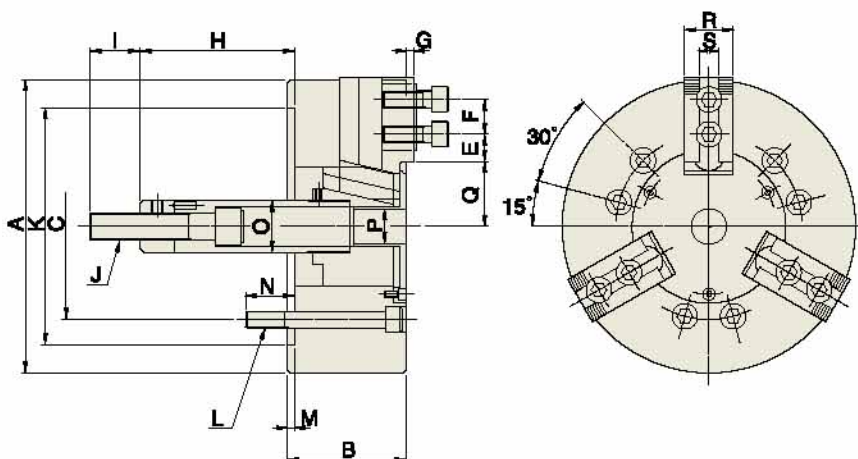

■規格 SPECIFICATIONS

型式 Model		尺寸 Dim	V-206	V-208	V-210	V-212	V-215
爪行程 Jaw Stroke (mm)			8.5	8.8	8.8	10.5	16
柱塞行程 Plunger Stroke (mm)			20	21	25	30	35
夾持範圍 Gripping range	最大 Max mm		165	210	254	304	381
	最小 Min mm		12	12	16	18	68
最大推力 Max. Pull Force (kgf)			1835	2549	2957	4181	8362
最高轉速 Max. Speed (r.p.m)			5000	4000	3500	3000	2800
最大夾持力/油壓壓力 Max. Gripping Force (kgf)/(kgf/cm ²)			5253 25.5	7548 24.5	11013 28.6	15807 27.5	25391 30.6
重量 Weight (kg)			12	22.8	34.4	59	100.6
慣性矩 Moment of Inertia (kgf.m ²)			0.045	0.137	0.3	0.725	1.8
適合油壓缸 Matching Cylinder			MH100	MH125	MH125	MH150	MH200
適合之硬爪 Matching Hard Jam			HJ06	HJ08	HJ10	HJ12-1	HJ15-1
適合之軟爪 Matching Soft Jam			HC06	HC08	HC10	HC12-1	HC15-1

■尺寸表 DIMENSIONS:

型式 Model		尺寸 Dim	V-206	V-208	V-210	V-212	V-215
A			165	210	254	304	318
B			74	85	89	106	114
K(H6)			140	170	220	220	300
M			5	5	5	6	6
C			104.78	133.35	171.45	171.45	235
P			21	25	34	34	—
L			6-M10	6-M12	6-M16	6-M16	6-M20
N			14	20	18	22	29
F			20	25	30	30	43
Q	Max.		37.8	46.3	51.1	61	77.5
	Min.		33.55	41.9	46.7	55.75	69.5
E	Max.		18	22.5	37.5	47	50.25
	Min.		7.5	9	10.5	11	23.25
H	Max.		104.6	132	158	163	104
	Min.		84.6	111	133	133	69
S			12	14	16	18	25.5
R			31	35	40	50	50
J			M16X2.0	M20X2.5	M20X2.5	M20X2.5	M30X3.5
G			4	5	5	5	2
O			34	38	45	50	60
I			36	36	36	36	55