

3-JAW WEDGE TYPE THROUGH-HOLE  
POWER CHUCK (WITHOUT ADAPTOR)

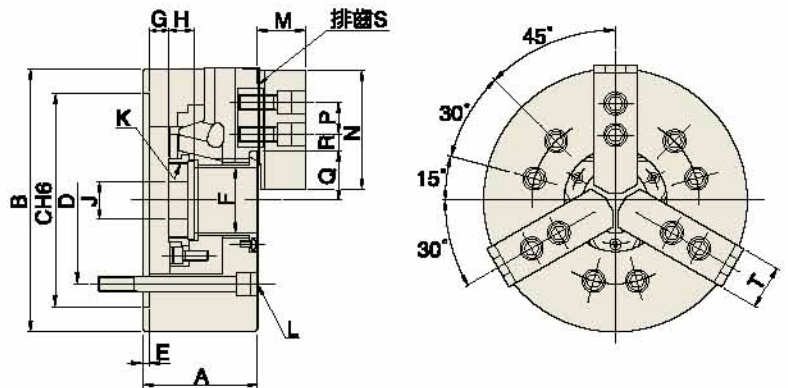

把握力性能曲線 TF3B

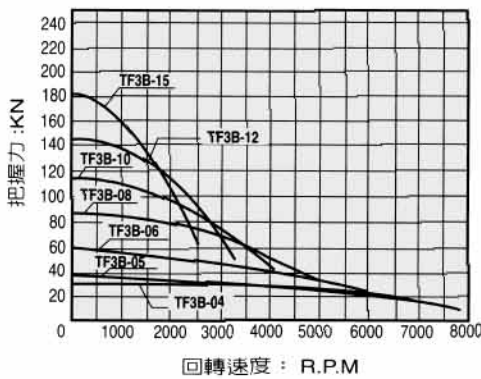

尺寸表 DIMENSIONS

規格 Series Type	TF3B							
	4	5	6	8	10	12	15	
A	59	60	81	91	100	110	133	
B	110	135	169	210	254	304	381	
C <sub>max</sub>	85	110	140	170	220	220	300	
D	70.6	82.55	104.78	133.35	171.45	171.45	235	
E	4	4	5	5	5	6	6	
F	28	33	45	52	75	91	117.5	
G	Max	3.5	1	11	14.5	8.5	23	
	Min	-6.5	-9	-1	-1.5	-10.5	-15	0
H	17.5	20	19	20.5	25	28	35	
J	12	12	20	30	45	50	50	
K	Max	M32x1.5	M40x1.5	M55x2	M60x2	M85x2	M100x2	M130x2.0
	L	3-M10x50	3-M10x60	5-M10x80	6-M12x90	6-M16x100	6-M16x110	6-M20x150
M	24	26	29	39	43	51	61	
N	49.5	54	66	95	110	111	135	
P	14	14	20	25	30	30	43	
Q	Max	23	26.5	32	38.7	51	61.3	70
	Min	20.3	23.8	29.25	35	46.6	56	64.7
R	Max	11.25	19.75	22.75	29.75	33.75	45.75	64.75
	Min	6.75	7.75	9.25	14.75	14.25	16.75	20.25
S	1.5	1.5	1.5	1.5	1.5	1.5	1.5	
T	23	23	32	37	40	50	50	

規格 SPECIFICATIONS

性能 Specification	型式 Model	TF3B						
		4	5	6	8	10	12	15
爪之行程 (直徑) Jaw Movement (Dia) (mm)		5.4	5.4	5.5	7.4	8.8	10.6	10.6
柱塞行程 Plunger Stroke (mm)		10	10	12	16	19	23	23
最大、最小把握徑 Recommended external chucking Diameter for standard soft top jaw(mm)	最大 Max.	110	135	165	210	254	304	381
	Min.	5	10	10	12	16	38	40
最高使用迴轉速 Max. speed (R.P.M)		8000	7000	6000	4900	4200	3300	2600
最大拉桿推力 Max. D.B. pull (KN (kgf))		14 (1428)	17.5 (1784)	22 (2243)	34 (3467)	43 (4385)	55 (5608)	7240
把握力 Clamping-force at Max. D.B. pull (Total jaw force) (KN (kgf))		28.5 (2906)	36 (3671)	57 (5812)	86 (8769)	111 (11319)	144 (14686)	180 (18355)
GD <sup>2</sup> Moment of Inertia w.D2 (kgf·m <sup>2</sup> )		0.026	0.07	0.23	0.68	1.26	2.95	9.09
重量 Weight with standard soft top jaws (kg)		4	6.7	12.5	22.6	37	61	120
搭配油壓缸 Matching cylinder	最高使用壓力 Max. pressure to operate chuck(kgf/m <sup>2</sup> )	RC 4 / 24.5	5 / 29.5	6 / 28.5	8 / 27	10 / 27.5	12 / 27.5	15 / 23.5