

# 超短型中空迴轉油壓缸 (一)



## SHORT TYPE ROTATING HYDRAULIC CYLINDER WITH THROUGH-HOLE AND SAFETY DEVICE

專利產品字號：  
 台灣：PAT.199970號 (Taiwan)  
 大陸：PAT.ZL01.2.08005.5號 (China)  
 美國：PAT.US6640686B2號 (U.S.A)



- 超短，大孔徑型迴轉油壓缸，全長僅為從來型的2/3。
- 內建逆止閥自鎖機構及壓力洩壓閥。
- 安裝時可由後端鎖固之。
- Super short form, light weight large Through-Hole, just as 2/3 of typical model length.
- Built-in safety check valves and pressure relief valves.
- Can screw it from the rear end of the cylinder when mounting.

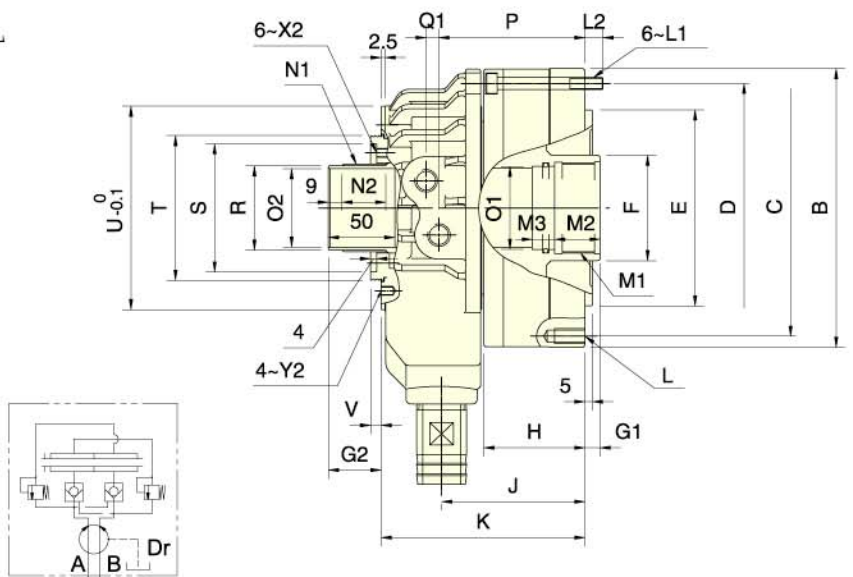
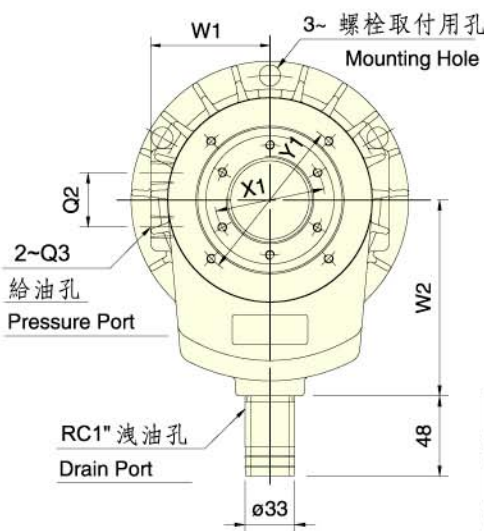

保留規格修改的權利  
 Subject to technical changes.

規格 Spec. 型號 Model	活塞面積 Eff. piston area cm <sup>2</sup>		行程 mm Piston stroke	最高迴轉數 min <sup>-1</sup> (r.p.m) Max. speed	最高使用壓力 MPa Max. pressure (kgf/cm <sup>2</sup> )	I kg·m <sup>2</sup> Moment of inertia	重量 kg Weight	總洩漏量 lit./min. Total oil leakage			
	伸側 Extend	拉側 Retract									
TK528	73.0	69.7	12	8000	4.5 (45)	0.012	6.2	3.0			
TK533									15	7000	6.0
TK643											
TK646	105.0	93.9	7.5								
TK646A				135.3		125.0	9.2				
TK846	165.9	144.9	12.4								
TK852				20		6300	11.8				
TK1068	25	5500	17.8								
TK1075				0.065		16.8					
TK1078	16.5	4.2									

寸法 Size 型號 Model	A 內徑 I.D	B	C	D	E h7	F	G1		G2		H	J	K	L	L1	L2	M1	M2	M3
							max.	min.	max.	min.									
TK528	105	141	125	110	45	12	0	37	25	50	78.5	118	6-M10x20	M8x55	15	M38x1.5	25	13	
TK533																			
TK643																			
TK646	125	156	140	120	65	15		40	57	85	126	M8x65	M50x2						
TK646A														128	162	147	130	70	20
TK846	145	185	170	165	98	25		50	73	107	157	M10x80	17						
TK852														170	212	190	160	98	25
TK1068	170	212	190	160	98	25		50	73	107	157	M10x80	17						
TK1075														170	212	190	160	98	25
TK1078																			

寸法 Size 型號 Model	N1	N2	O1 H8	O2 H8	P	Q1	Q2	Q3	R g7	S H7	T	U	V	W1	W2	X1	X2	Y1	Y2															
TK528	M39x1.5	26	35	28	80	30	RC1/4	37	62	70	98	6	62	110	49	83	M6x6	98	M5x6															
TK533																				29	50	46	88	8.5	36	RC3/8	50	76	85	116	75	120	64	M6x6
TK643																																		
TK646	M52x1.5	29	50	46	88	8.5	36	RC3/8	50	76	85	116	75	120	64	M6x6																		
TK646A																	M58x1.5	29	50	46	88	8.5	36	RC3/8	50	76	85	116	75	120	64	M6x6		
TK846	M58x1.5	29	50	46	88	8.5	36	RC3/8	50	76	85	116	75	120	64	M6x6																		
TK852																	M84x2	33	80	75	109	12	40	RC1/2	81	108	121	164	98	160	98	M6x8	155	M6x8
TK1068	M84x2	33	80	75	109	12	40	RC1/2	81	108	121	164	98	160	98	M6x8																		
TK1075																	M86x2	33	80	75	109	12	40	RC1/2	81	108	121	164	98	160	98	M6x8	155	M6x8
TK1078	M86x2	33	80	75	109	12	40	RC1/2	81	108	121	164	98	160	98	M6x8																		

# 超短型中空迴轉油壓缸 (二)



## SHORT TYPE ROTATING HYDRAULIC CYLINDER WITH THROUGH-HOLE AND SAFETY DEVICE

專利產品字號：  
 台灣：PAT.199970號 (Taiwan)  
 大陸：PAT.ZL01.2.08005.5號 (China)  
 美國：PAT.US6640686B2號 (U.S.A)



- 超短，大孔徑型迴轉油壓缸，全長僅為從來型的2/3。
- 內建逆止閥自鎖機構及壓力洩壓閥。
- 安裝時可由後端鎖固之。
- Super short form, light weight large Through-Hole, just as 2/3 of typical model length.
- Built-in safety check valves and pressure relief valves.
- Can screw it from the rear end of the cylinder when mounting.

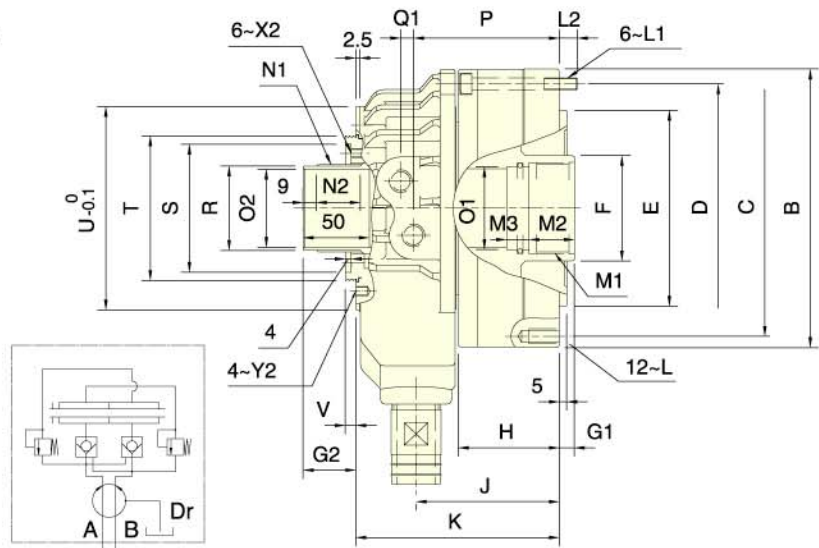
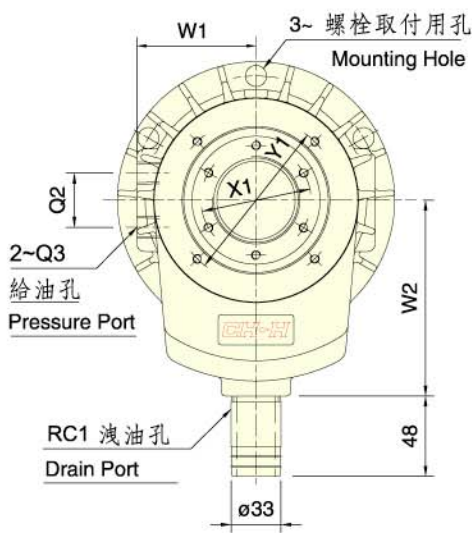

保留規格修改的權利  
 Subject to technical changes.

規格 Spec. 型號 Model	活塞面積 Eff. piston area cm <sup>2</sup>		行程 mm Piston stroke	最高迴轉數 min <sup>-1</sup> (r.p.m) Max. speed	最高使用壓力 MPa Max. pressure (kg/cm <sup>2</sup> )	I kg·m <sup>2</sup> Moment of inertia	重量 kg Weight	總洩漏量 lit./min. Total oil leakage
	伸側 Extend	拉側 Retract						
TK1287	234.0	217.5	30	3800	4.0 (40)	0.092	26.5	4.5
TK1291								
TK1511	356.5	335.3		3000	3.5 (35)	0.38	53.6	7.0
TK1512								
TK2114	373.2	336.1	35	2500		0.54	58.2	8.0

寸法 Size 型號 Model	A	B	C	D	E	F	G1		G2		H	J	K	L	L1	L2	M1	M2	M3	
	內徑 I.D				h7		max.	min.	max.	min.										
TK1287	200	245	215	225	180	110	30	0	55	25	87	127	185	M12x24	M10x95	18.5	M95x2	35	15	
TK1291																	M100x2			
TK1511	250	305	275	280	230	140	35	60	60	115	154	224	M16x32	M12x110	22.5	M12x120	17.5	M120x2	45	20
TK1512																		M130x2		
TK2114	265	320	295	240	165	165	35	60	60	115	173.5	247.5		M12x120	17.5	M155x2				

寸法 Size 型號 Model	N1	N2	O1 H8	O2 H8	P	Q1	Q2	Q3	R g7	S H7	T	U	V	W1	W2	X1	X2	Y1	Y2
	TK1287	M99x2	38	90	87	128.5	15	45	RC1/2	96	120	138	180	7	110	185	108	M6x10	165
TK1291	95			91															
TK1511	M129x2	38	115	110	152	17	50	RC1/2	126	150	170	227	7	134	210	138	M6x10	210	M6x10
TK1512			125	120															
TK2114	M149x2	38	145	140	170	17	50	RC1/2	146	170	190	250	7	145	160	138	M6x10	230	M6x10





# 超短型中空迴轉油壓缸 (三)

## SHORT TYPE ROTATING HYDRAULIC CYLINDER WITH THROUGH-HOLE AND SAFETY DEVICE

專利產品字號：  
 台灣：PAT.199970號 (Taiwan)  
 大陸：PAT.ZL01.2.08005.5號 (China)  
 美國：PAT.US6640686B2號 (U.S.A)



- 全新短型設計，大孔徑型迴轉油壓缸。
- 內建逆止閥自鎖機構及壓力洩壓閥。
- Brand-new design, short form, light weight large through-hole.
- Built-in safety check valves and pressure relief valves.

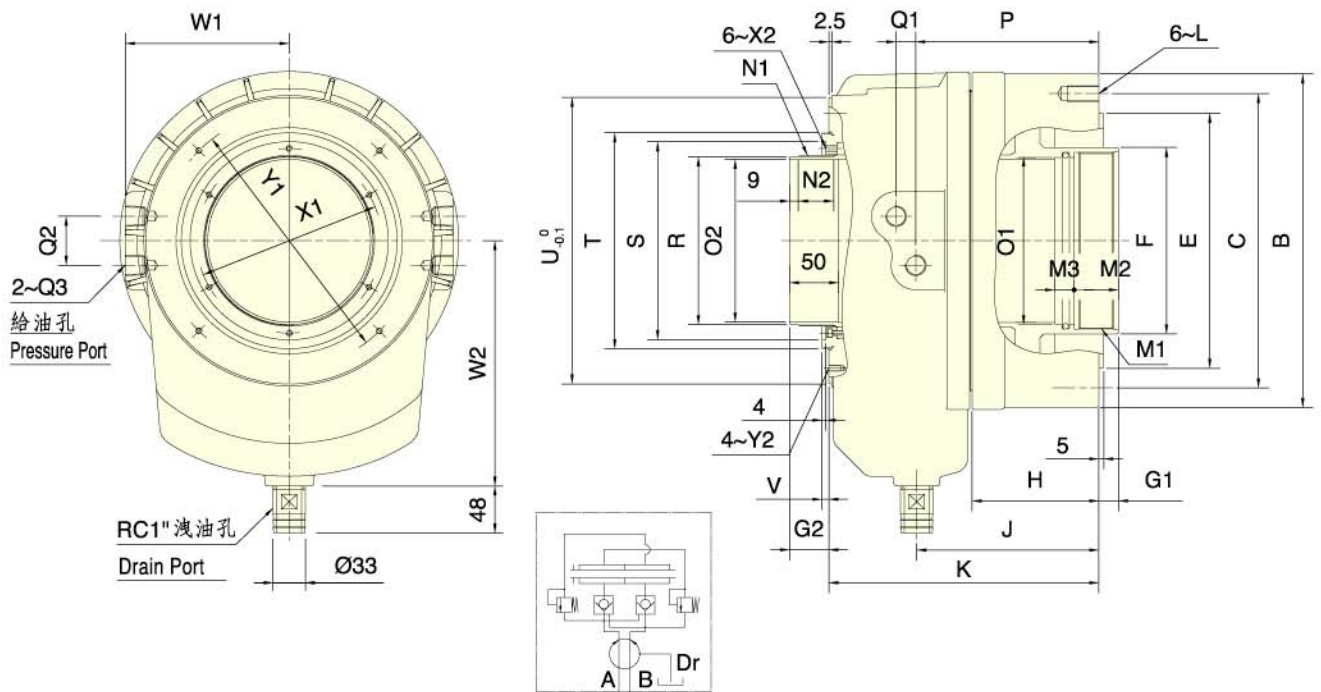

保留規格修改的權利  
 Subject to technical changes.

規格 Spec. 型號 Model	活塞面積 Eff. piston area cm <sup>2</sup>		行程 mm Piston stroke	最高迴轉數 min <sup>-1</sup> (r.p.m) Max. speed	最高使用壓力 MPa Max. pressure (kgf/cm <sup>2</sup> )	I kg·m <sup>2</sup> Moment of inertia	重量 kg Weight	總洩漏量 lit./min. Total oil leakage
	伸側 Extend	拉側 Retract						
TK2416	418.4	375.4	35	2000	3.0 (30)	1.12	78.0	9.0
TK2416L			51					
TK2820	526.2	472.6		1600		2.4	134.0	10.0

寸法 Size 型號 Model	A 內徑 I.D	B	C	E h7	F	G1		G2		H	J	K	L	M1	M2	M3
						max.	min.	max.	min.							
TK2416	290	340	300	260	190	35		60		129	185.5	275	M16x32	M180x3	45	20
TK2416L							0	76	25	145	201.5	291				
TK2820	340	395	360	320	235	51		76		152	212.5	316	M20x40	M220x3		

寸法 Size 型號 Model	N1	N2	O1 H8	O2 H8	P	Q1	Q2	Q3	R g7	S H7	T	U	V	W1	W2	X1	X2	Y1	Y2
TK2416L	202.5																		
TK2820	M218x2	52	210	205	216	21			215	262	285	360		202.5	300	240	M6x12	320	