

# CL 3-JAW SOLID POWER CHUCKS

## 三爪中實油壓夾頭

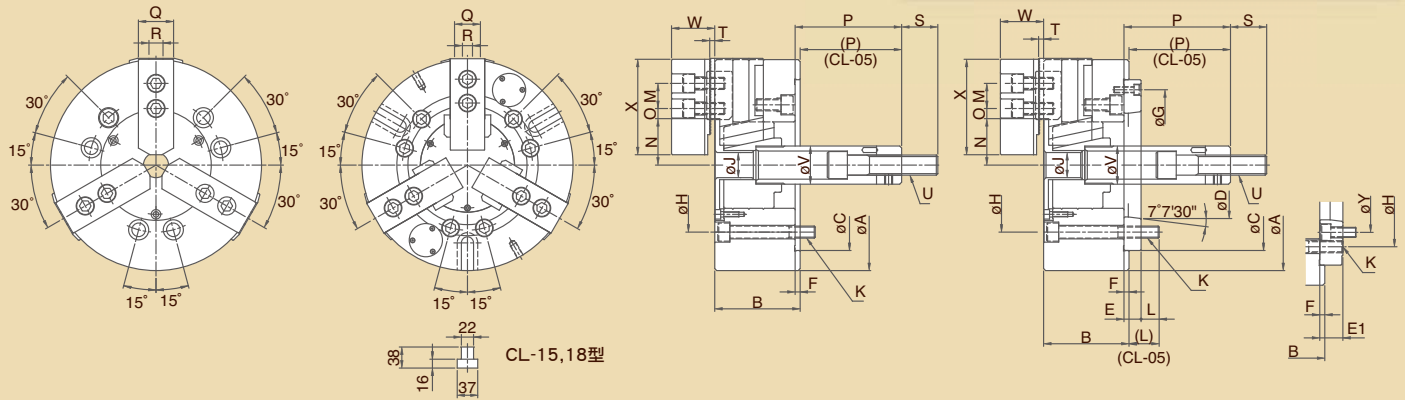

### 尺寸圖 » Dimensions



### 規格表 » Specifications

單位/UNIT:mm

型式/規格 MODEL /SPEC.	主軸鼻端番號 Nose Of Spindle	A	B	C (h6)	D	E	E1	F	G	H	J	K	L	M
CL-05	A <sub>2</sub> -4	135	55	80	63.513	--	--	7	--	100	--	3-M8x1.25P	14	14
CL-06	A <sub>2</sub> -5	165	74	140	82.563	15	--	5	116	104.8	21	6-M10x1.5P	14	20
CL-08	A <sub>2</sub> -6(A <sub>2</sub> -5)	210	85	170	106.375	17	23	5	150	133.4	25	6-M12x1.75P	18	25
CL-10	A <sub>2</sub> -8(A <sub>2</sub> -6)	254	89	220	139.719	18	28	5	190	171.4	34	6-M16x2P	25	30
CL-12	A <sub>2</sub> -8	304	106	220	139.719	18	--	6	190	171.4	34	6-M16x2P	25	30
CL-15	A <sub>2</sub> -11	381	114	300	196.869	22	--	6	260	235	--	6-M20x2.5P	32	43
CL-18	A <sub>2</sub> -11	450	114	300	196.869	22	--	6	260	235	--	6-M20x2.5P	32	43

型式/規格 MODEL /SPEC.	N max.	N min.	O max.	O min.	P max.	P min.	Q	R	S	T	U	V	W	X	Y
CL-05	30.4	27.2	17.1	9.6	9	-6	25	10	35	2	M12x1.75P	28	31	62	--
CL-06	37.8	33.25	15.1	9.1	101.5	81.5	31	12	36	4	M16x2P	34	39	73	--
CL-08	46.3	41.9	22.1	10.1	127	106	35	14	36	5	M20x2.5P	38	42	95	104.8
CL-10	51.4	47	30.6	9.6	158	133	40	16	36	5	M20x2.5P	45	46	110	133.4
CL-12	60.7	55.45	48.6	12.6	163	133	50	18	36	5	M20x2.5P	50	54	129	--
CL-15	69.05	60.97	58.05	40.05	104	69	62	25.5	55	7	M30x3.5P	60	68	165	--
CL-18	99.46	91.38	58.05	40.05	92	57	62	25.5	55	7	M30x3.5P	60	68	165	--

型式/規格 MODEL /SPEC.	柱塞行程 Plunger Stroke (mm)	爪行程 (直徑) Jaw Stroke [Diameter] (mm)	最高迴轉速 Max.Speed r.p.m.(min <sup>-1</sup> )	最大拉力 Max. Pull Force kgf (KN)	最大靜夾持力 Max. Gripping Force kgf (KN)	最大設定 油壓壓力 Max. Hydr. Pressure kgf/cm <sup>2</sup> (Mpa)	淨重 Weight (kg)	搭配 油壓缸型號 Matching Cylinder	夾持範圍 Gripping Range
CL-05	15	6.4	5500	800 (7.8)	2450 (24)	25 (2.5)	6	L0815	ø8~ø135
CL-06	20	8.5	5000	1730 (17)	5200 (51)	25 (2.5)	11.4	L1020(L1020R)	ø18~ø165
CL-08	21	8.8	4600	2440 (24)	7440 (73)	25 (2.5)	21.9	L1225(L1225R)	ø12~ø210
CL-10	25	8.8	4000	2850 (28)	10810 (106)	29 (2.8)	33.4	L1225(L1225R)	ø16~ø254
CL-12	30	10.5	3200	4080 (40)	15500 (152)	29 (2.8)	58.5	L1530(L1530R)	ø18~ø304
CL-15	35	16	3000	8260 (81)	25290 (248)	32 (3.1)	100.6	L2035(L2035R)	ø68~ø381
CL-18	35	16	2700	8260 (81)	25290 (248)	32 (3.1)	134.3	L2035(L2035R)	ø100~ø450